

**ALP**

**High Current Drivers**

**New Product Training**

**October, 2001**

# Target Markets High Current Drivers

**xDSL -CPE Modem  
- CO DSLAM**

**Cable Modem  
Cable Set-top Box  
Cable Telephony**

**CD R/W  
DVD – R/W**

# ADI's xDSL Component Strategy

## Line Driver Components for xDSL Modems

- **For CPE**
  - Reduce **Cost**
  - Reduce # of Power Supplies by increasing Output Current
  - Maximize Peak Power Drive (Voltage and Current)
  - Improve **Efficiency**
  - No Sacrifice of Distortion Performance- **Reach**
- **For Central Office**
  - Increase **Efficiency** (Reduce Power Dissipation = Density\*)
  - No Sacrifice of Distortion Performance- **Reach**
  - Maintain Peak Power Drive

\*Reduce Power Dissipation = Smaller Package = Increased Density = Lower System Cost

# AD8391 Low Cost, +3V to +12V xDSL Line Driver

- What is it?
  - The AD8391 is a low cost xDSL line driver designed for xDSL CPE modems. The AD8391 has a flexible power supply that supports +3V to +12V designs supporting VoDSL applications. The AD8391 can be used as general low cost CPE line driver or as a special purpose part.
- Features
  - The AD8391 drives minimum 250mA of current while maintaining -95dBc of SFDR at 100kHz on +12V.
  - When using the AD8391 in +3V mode it can drive a minimum of 100mA of current while maintaining -94dBc of SFDR at 100kHz .
  - The AD8391 is available in an 8-pin SOIC and still supports a power down mode.

# AD8391 - Twisted Pair Driver

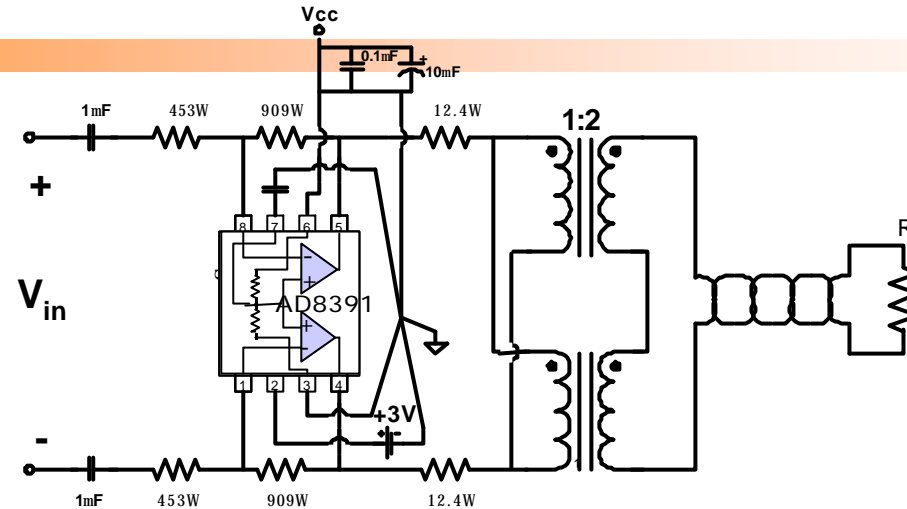

Increasing the turns ratio of the transformer will allow more power to be delivered to the line while maintaining the the same level of distortion

But it also means that more power will be dissipated by the driver!!

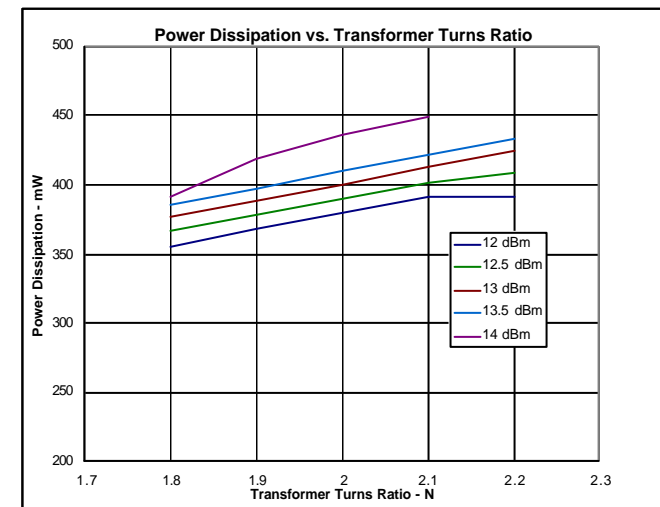
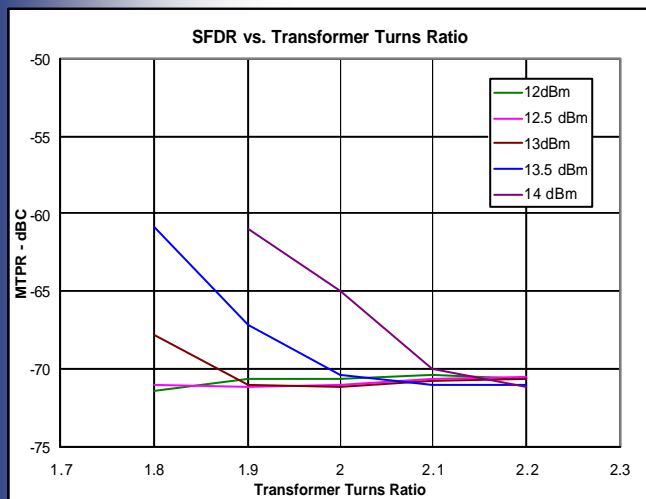

# AD8391 Twisted Pair Driver

- Packaging:
  - AD8391 8 lead SOIC
- Milestones:
  - AD8391 Samples Now
  - AD8391 M/P October 2001

# AD8393 xDSL CO Line Driver

## Supply on Peak Amplifier

- What is it?
  - Driver amplifier for xDSL-CO applications. It provides 23.3dBm output power. Very low power dissipation based on proprietary “Supply on Peak” active circuitry enabling the lowest possible port density.
- Features
  - Low power operation
    - 526mW total power dissipation (typical 1:1.1 turns ratio), not including line power, +/- 6V Voltage Supply
  - Shutdown to 1mA
  - Current Feedback Amplifiers
  - High Output Voltage and Current Drive
    - 23.3dBm Differential Drive for a DMT Signal
    - 425mA Peak Output Drive Current,  $R_L = 25 \Omega$
  - Low Distortion
    - -70dBc @ 1MHz MTPR,  $R_L = 25 \Omega$

# AD8393 Supply On Peak

- Full Rate ADSL CO Operation on Supplies of +/- 6V or Single +12V
- Proprietary Adaptive Circuitry Temporarily Pumps Up Supply Rails to Handle DMT Peaks
- Innovative architecture allows lowest power dissipation for any CO driver available

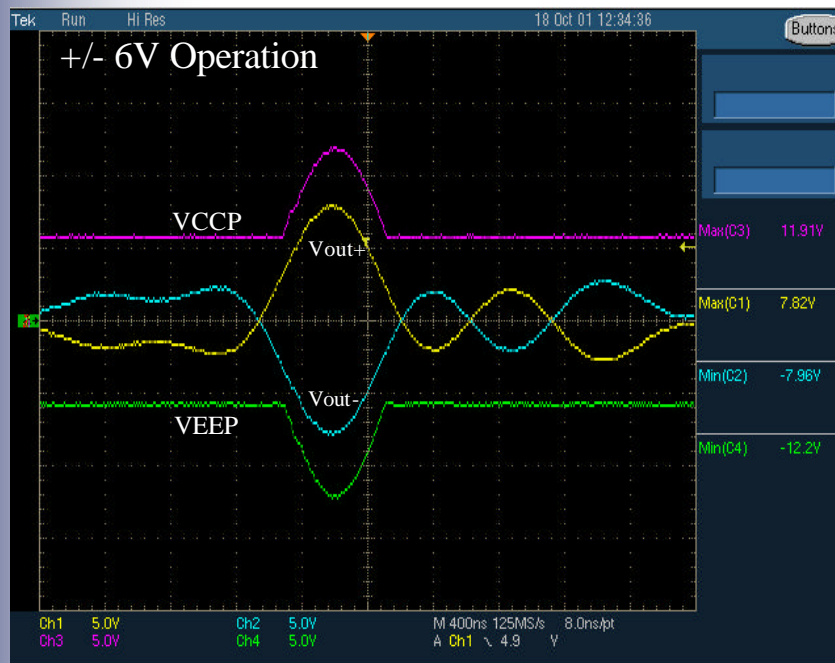

- VCCP and VECP are the positive and negative rails to the amplifier, these sit about 300mV inside the supply rails at approximately +/- 5.7V respectively
- Note the differential output voltage of approx 16Vp-p on +/- 6V supplies

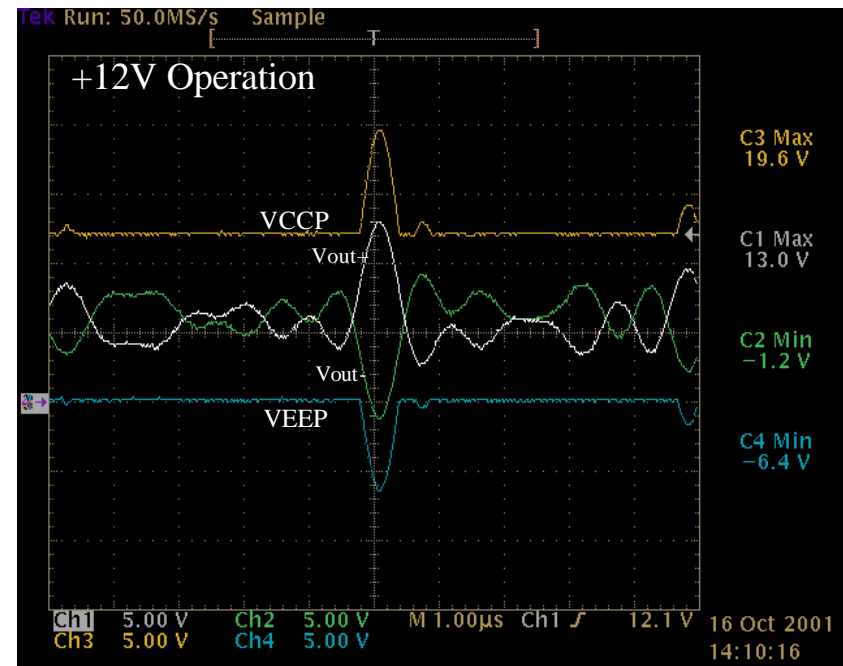

- Operating from a single +12V supply, VCCP is at +11.7V and VECP is at +0.3V
- During single supply operation even the rail at ground is pumped to accommodate the negative going peak
- The differential outputs can again be seen extending beyond both rails



# AD8393 xDSL CO Line Driver

- Packaging:
  - 5mm x 5mm CSP
  - 28 lead TSSOP
- Milestones:
  - Samples                      Now
  - M/P                              March '02
- Preview of Follow-on Version:
  - Target <500mW power dissipation.
  - Samples available in March '02

# **Cable Drivers**

***AD8327/28/29***

**Low Cost DOCSIS Drivers**

# AD8327/28/29 +5V CATV Line Drivers

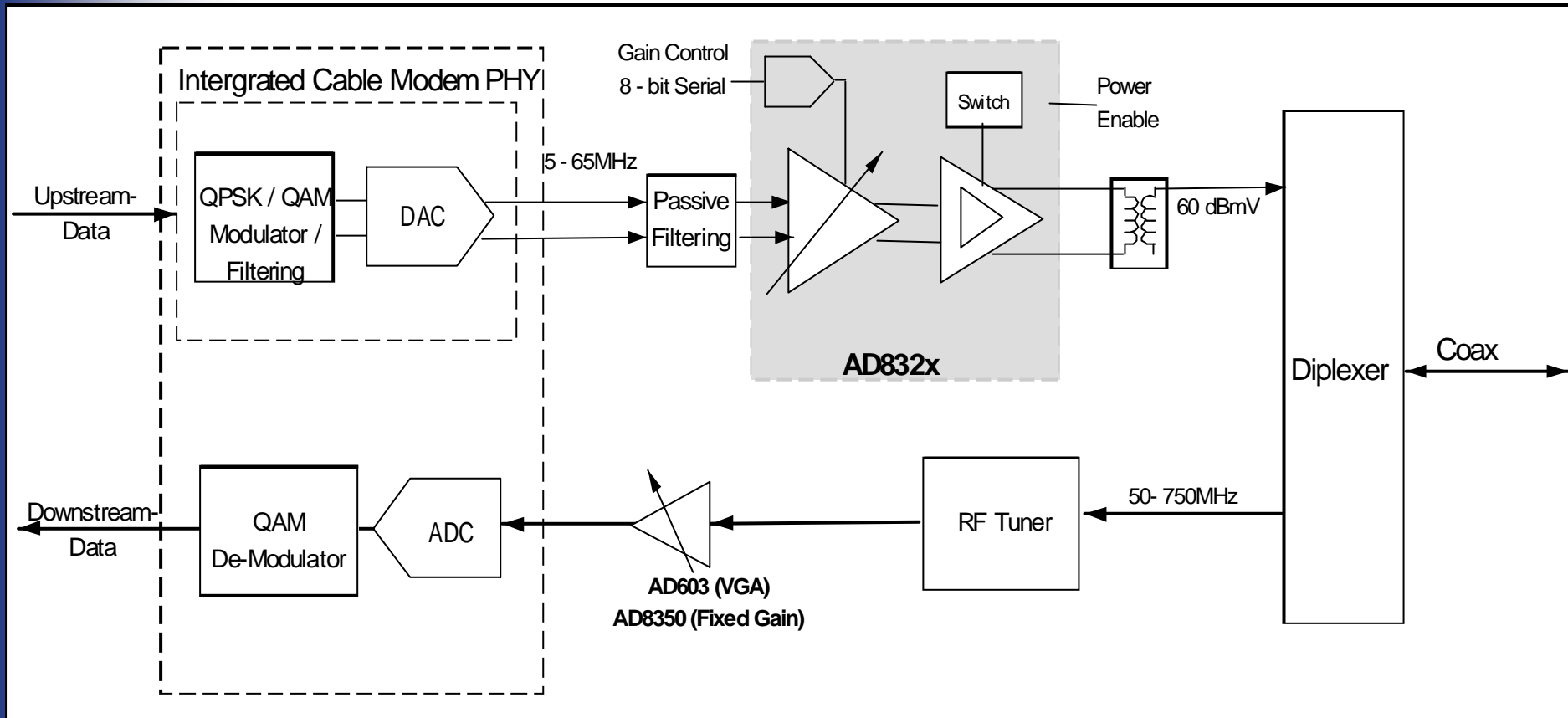

# AD8327/28/29

## +5V CATV Line Drivers

- Key Applications Information
  - Gain Range
    - DOCSIS needs a signal level from 8dBmV-58dBmV so a wide gain range is important because of losses in the signal chain. Minimum gain from DOCSIS specification is 50dB.
    - The AD8328, AD8329 and AD8327 (when combined with fine step attenuator) exceed gain range of DOCSIS specification.
  - Low Distortion
    - Low Distortion allows maximum bit rate through the cable system. Minimum DOCSIS distortion specification is  $-47\text{dBc}$ .
    - Distortion performance for the AD8328, AD8329 and AD8327 exceed DOCSIS specifications.
  - Low Glitch
    - Low transient (on/off) glitch is important to keep noise in the cable system low. DOCSIS specifies a minimum glitch of 7mVp-p for minimum gain.
    - The AD8328, AD8329 and AD8327 fully meet DOCSIS glitch specification.
  - Cost
    - Low solution cost is important since cable modems are a consumer product.
    - AD8327 eliminates output transformer which lowers solution cost, while the AD8328 and AD8329 have been designed in low cost processes combined with a low cost package.

# Application Information – Cable Line Drivers

	<b>AD8327 (+5V)</b>	<b>AD8328* (+5V)</b>	<b>AD8329* (+5V)</b>
<b>Output Level</b>	+60 dBmV	+60 dBmV	+64 dBmV
<b>Step Size</b>	6 dB	1 dB	1 dB
<b>Gain Range</b>	48 dB	59 dB	59 dB
<b>Transmit Disable / Sleep Mode Current</b>	13mA / 4mA	2.6mA / 10 $\mu$ A	3mA / 10 $\mu$ A
<b>Special Features</b>	Single Output Ramp Pin to Control Transients	Low Cost LFCSP Available Ramp Pin to Control Transients	Low Cost LFCSP Available Ramp Pin to Control Transients

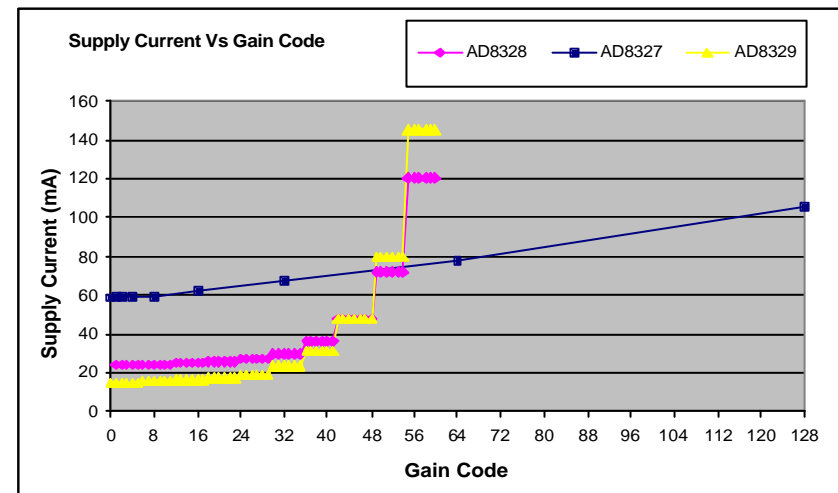
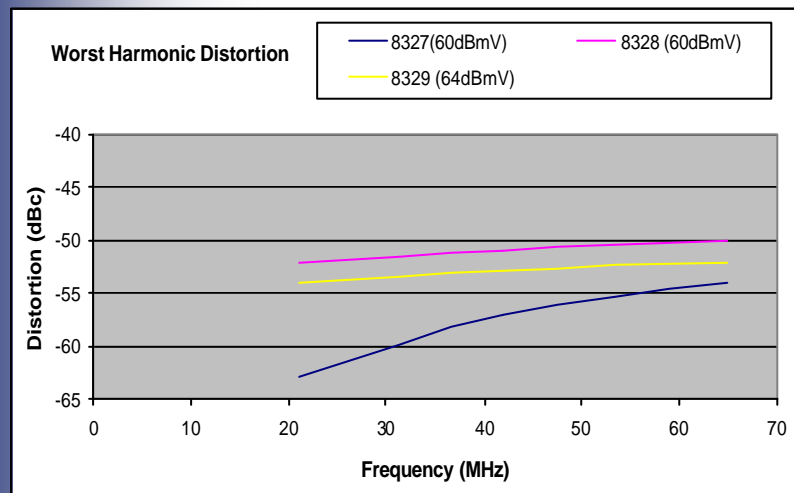

- Distortion for all three parts exceeds DOCSIS and EuroDOCSIS specifications by at least 3dB.

- Lower gain codes draw less current. This means that the devices only draw the current they need for optimum performance and energy conservation.

\*All data for AD8328 and AD8329 is preliminary

# AD8327/28/29

## +5V CATV Line Drivers

- What are they?
  - The **AD8328/29** are differential output CATV line drivers for use in Cable Modems and Set Top Box
- Features
  - For use with all DOCSIS\* and EuroDOCSIS Cable Chipsets
  - **Wide gain range of 59dB**
  - 1 dB step size
  - Low output distortion of 50dBc at 65MHz and 11dBm (AD8328)
  - Low output distortion of 52dBc at 65MHz and 15dBm (AD8329)
  - Small LFCSP package
  - Low Cost
- \*DOCSIS – Data Over Cable System Interface Standard
- What are they?
  - The **AD8327** is a single-ended output CATV line driver for use in CPE Cable Modems
- Features
  - **Single-ended output which eliminates the output transformer in a Cable Modem design.**
  - For use with Cable Chipsets with integrated attenuator(Broadcom) for DOCSIS & EuroDOCSIS applications.
  - Wide gain range of 48dB
  - 6dB step size
  - Low output distortion of 54dBc at 65MHz and 11dBm
  - Low solution cost (no transformer needed)

# AD8327/28/29 Cable Drivers

- Packaging:
  - AD8327 20 lead TSSOP
  - AD8328 20 lead CSP & 20 lead QSOP
  - AD8329 20 lead CSP & 20 lead TSSOP (E-Pad)
- Milestones:
  - AD8327 Samples Now
  - AD8328 Samples November 2001
  - AD8329 Samples April 2002
  - AD8327 M/P Now
  - AD8328 M/P June 2002
  - AD8329 M/P August 2002

# Laser Diode Drivers



# Laser Diode Driver Product Preview

**The Laser Diode Driver is a +5V, high current driver optimized for driving a laser diode in CD/RW and DVD-REC drives.**

## FEATURES

- **Current Controlled output current source with 3 input channels**
- **Output current for Channel 2 - 250mA**
- **Output current for Other Channels - 125mA**
- **Total output current to 375mA**
- **Rise time / Fall time of 1 ns**
- **On-chip 100MHz to 400MHz Oscillator**
- **Single 5V power supply (+/-10%)**
- **Low Output Overshoot**
- **Low Power Consumption**
- **Small 4mm x 4mm LFCSP**

## APPLICATIONS

- **CD-RW drives**
- **DVD-RW, DVD+RW, DVD-RAM drives**
- **MO Drives**
- **Laser Diode Current Switching**

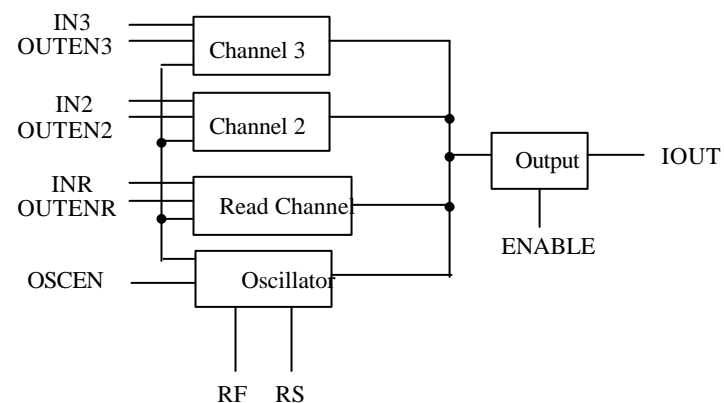

Figure 1. Block diagram of 3-Channel Laser Driver

# Laser Diode Driver Availability and Pricing

- Packaging:
  - 4mm x 4mm CSP
  - 16 lead QSOP
- Milestones:
  - Samples March 2002
  - M/P July 2002
- More Information:
  - Contact: Marco Baratta  
marco.baratta@analog.com  
781-937-1868